

CPSC 330

Computer Organization

Overview

- Course Schedule
- Introduction to Computer Organization
- Pre-requisite survey

About the Course - *Computer Organization*

■ **Catalog Description:**

- Study of computer organization and architecture. Examine functional organization of a computer including computer micro-operations, control organizations, basic instruction sets, addressing modes, CPU design, memory organization, and input-output organization. More advanced topics including pipeline and multiprocessors may also be introduced.

■ **Goals:**

- To provide an understanding of the basic performance criteria, organizational structures and functions of contemporary computer systems. The emphasis is to show the relationship between the hardware and software and to focus on concepts that are the basis for current computers.
- To become familiar with assembly language programming.

CPSC330 CompOrg: Dr. Gerousis

About the Book

***Computer Organization & Design,
The Hardware/Software Interface - Third Edition
Revised***



- Authors are recognized experts.
 - ❖ Patterson – UCB
 - ❖ Hennessy – Stanford
- It has lots of historical references.
- It is well written, organized, fairly easy reading (pace yourself).
- It will be the backbone of the course.

CPSC330 CompOrg: Dr. Gerousis

Course Schedule (Tentative)

- Week 1: Introduction & Computer Abstraction Model (Chap. 1)
- Week 2: Performance Measurement & Benchmarking (Chap. 4)
- Weeks 3-4: Assembly Language (Chap. 2)
- Exam 1 (Ch. 1,2,4)
- Week 5: Arithmetic & Logical Operations (Chap. 3)
- Weeks 6-8: Processor Datapath and Control (Chap. 5)
- Week 9: Pipelining (Chap. 6)
- Exam 2 (Ch. 3-5)
- Week 10: Memory Hierarchy, Cache, & Virtual Memory (Chap. 7)
- Week 11: I/O Devices & I/O Subsystems (Chap. 8)
- Week 12: November 21 - 25 Thanksgiving Break
- Week 13: Multiprocessors (Chap. 9)
- Week 14: Review
- Week 15: Final (Ch. 1-9)

CPSC330 CompOrg: Dr. Gerousis

Pentium IV processor chip

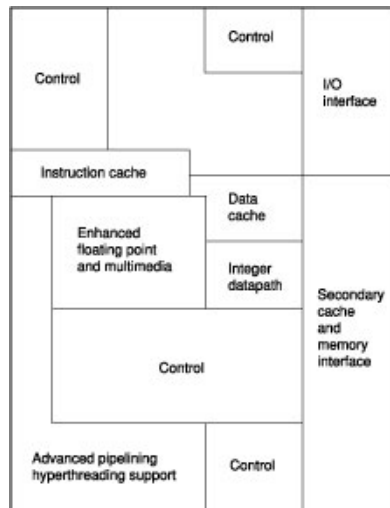

CPSC330 CompOrg: Dr. Gerousis

What is "Computer Architecture"?

Computer Architecture =
Instruction Set Architecture +
Machine Organization +

CPSC330 CompOrg: Dr. Gerousis

The Instruction Set: a Critical Interface

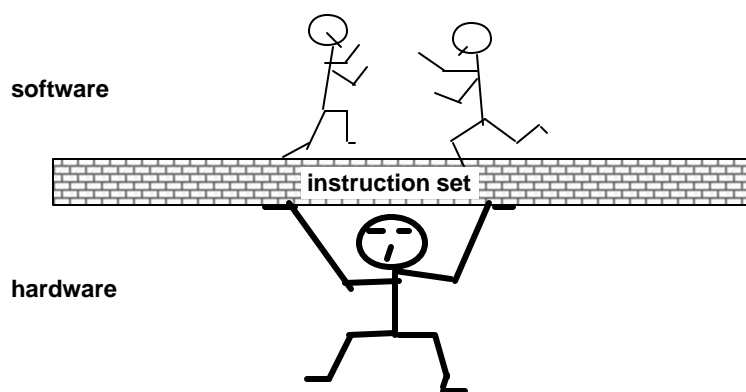

CPSC330 CompOrg: Dr. Gerousis

Instruction Set (IS) Architecture - continued

- A very important abstraction
 - interface between hardware and low-level software
 - standardizes instructions, machine language bit patterns etc. IS includes anything programmers need to know to make machines language program work correctly including instructions, registers, memory access, I/O devices, etc.

- Instruction set architectures:
 - 80x86/Pentium/K6, PowerPC, DEC Alpha, MIPS, SPARC, HP

CPSC330 CompOrg: Dr. Gerousis

From a high-level language to the language of the hardware

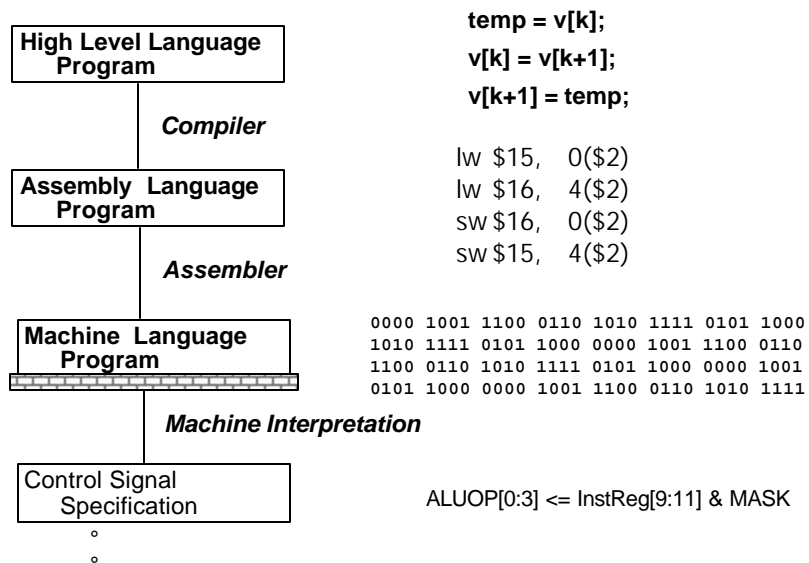

CPSC330 CompOrg: Dr. Gerousis

Computer Organization

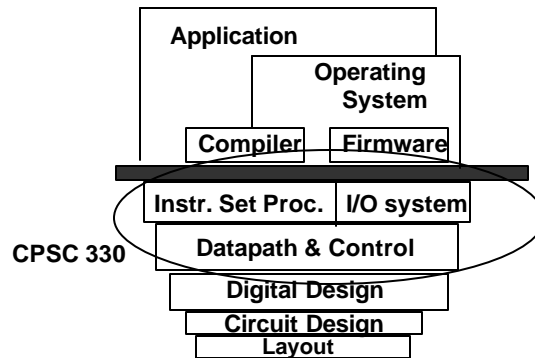

- Coordination of many *levels of abstraction*
- Under a rapidly *changing set of forces*

CPSC330 CompOrg: Dr. Gerousis

Forces on computer architecture

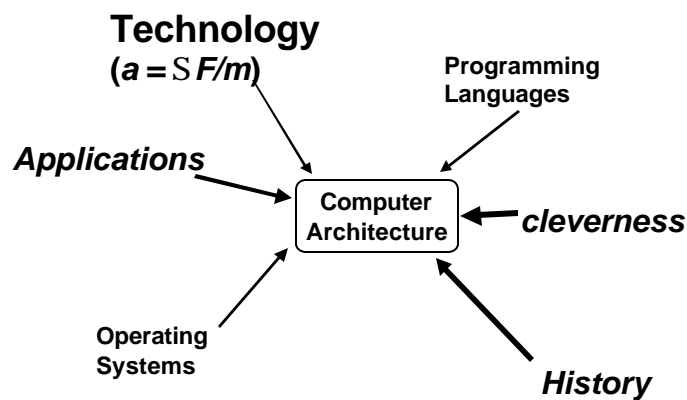

CPSC330 CompOrg: Dr. Gerousis

The big picture

- Since 1946 all computers have had 5 components

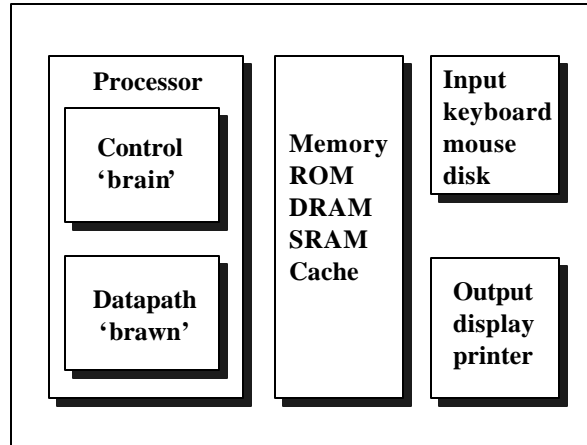

CPSC330 CompOrg: Dr. Gerousis

Sample Organization: It's all about communication

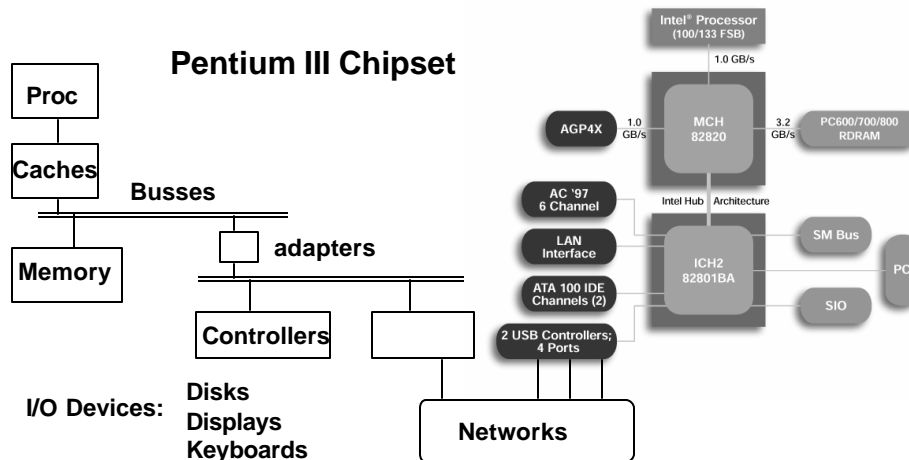

- All have interfaces & organizations

CPSC330 CompOrg: Dr. Gerousis

What is the significance of Computer Architecture?

- It impacts every other aspect of electrical engineering and computer science.
- It's exciting! Microprocessor performance growth "unmatched by other industries" [John Crawford, Intel fellow]

Processor speed has doubled every 18 months (1982-1996)
 — Cars would travel at 44,000 mph and get 16,000 miles/gal.
 — Air travel: L.A. to N.Y. in 22 seconds.

CPSC330 CompOrg: Dr. Gerousis

What is the significance of Computer Architecture?

Computer architecture is becoming more important as computer technology continues to advance.

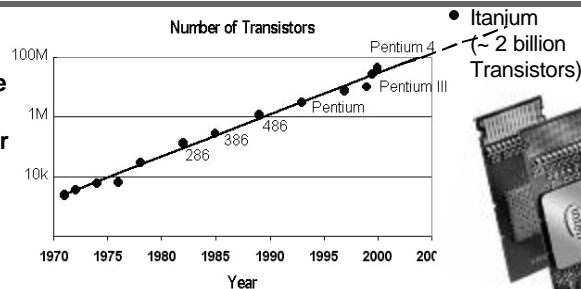

How does the nanometer compare to the thickness of a human hair?

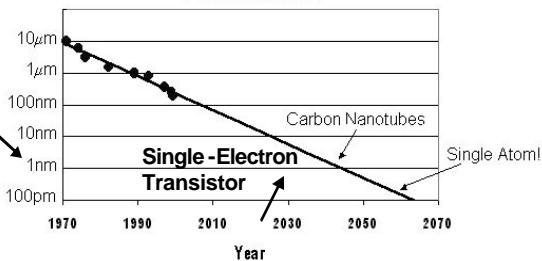

CPSC330 CompOrg: Dr. Gerousis

Why study Computer Architecture?

- If you want to call yourself a “computer scientist”
- Programmers and computer scientists who seek to build competitive versions of compilers, operating systems, databases and even applications will need to increase their knowledge of computer architecture and organization:
 - interface between the software and hardware
 - performance of a program
 - hardware techniques that affect performance

CPSC330 CompOrg: Dr. Gerousis

Next Time...

- Short History of computers
- Start chapter 4 (performance)

CPSC330 CompOrg: Dr. Gerousis